

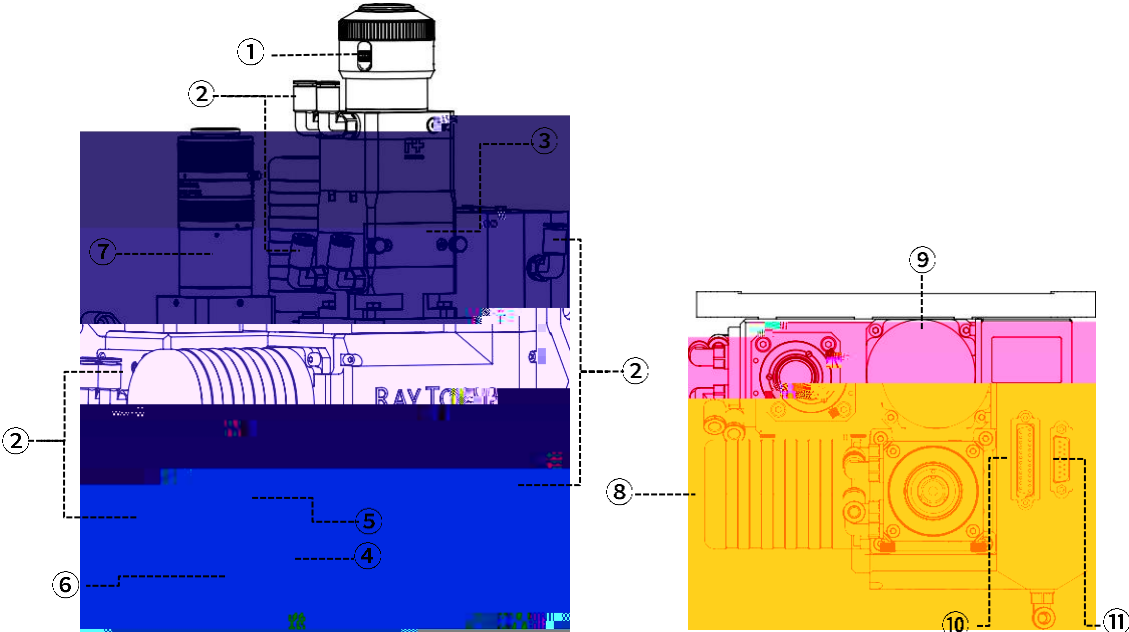

RAYTOOLS

RAYTOOLS





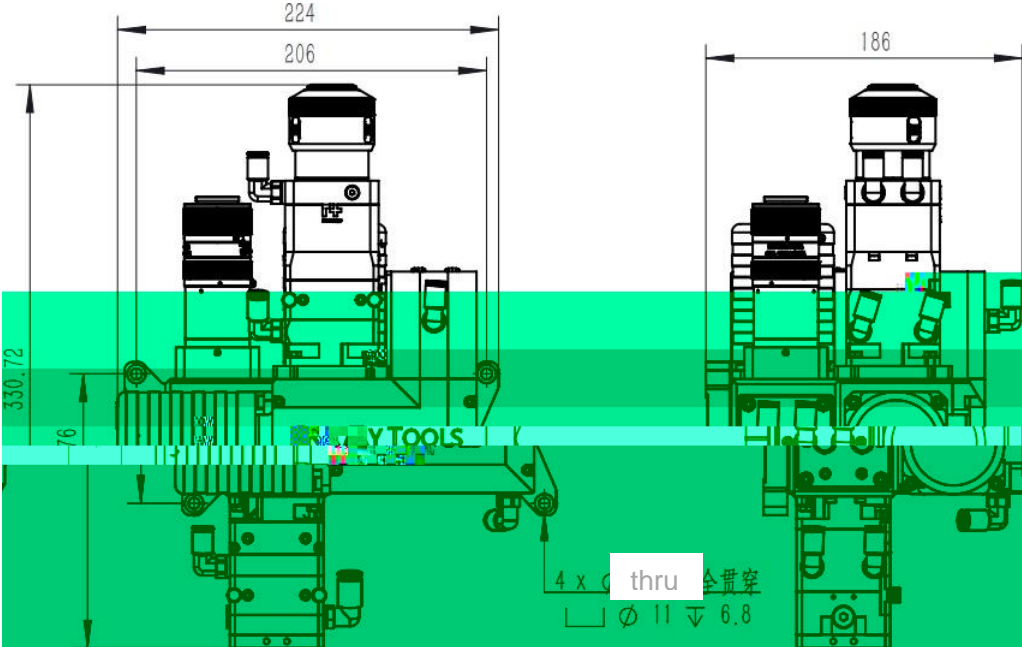

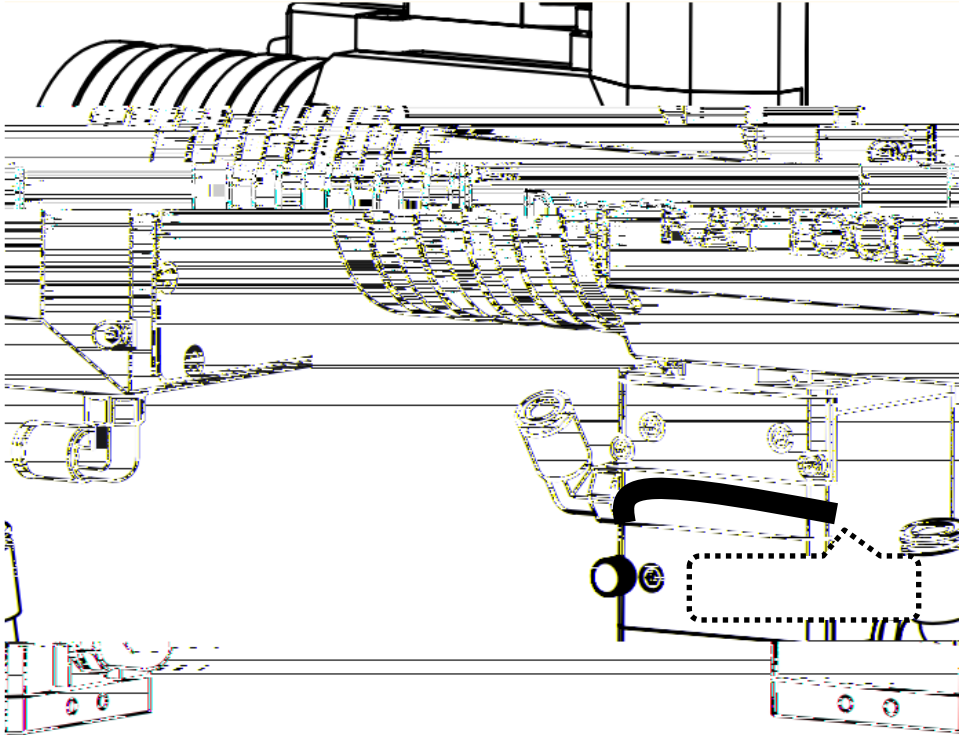

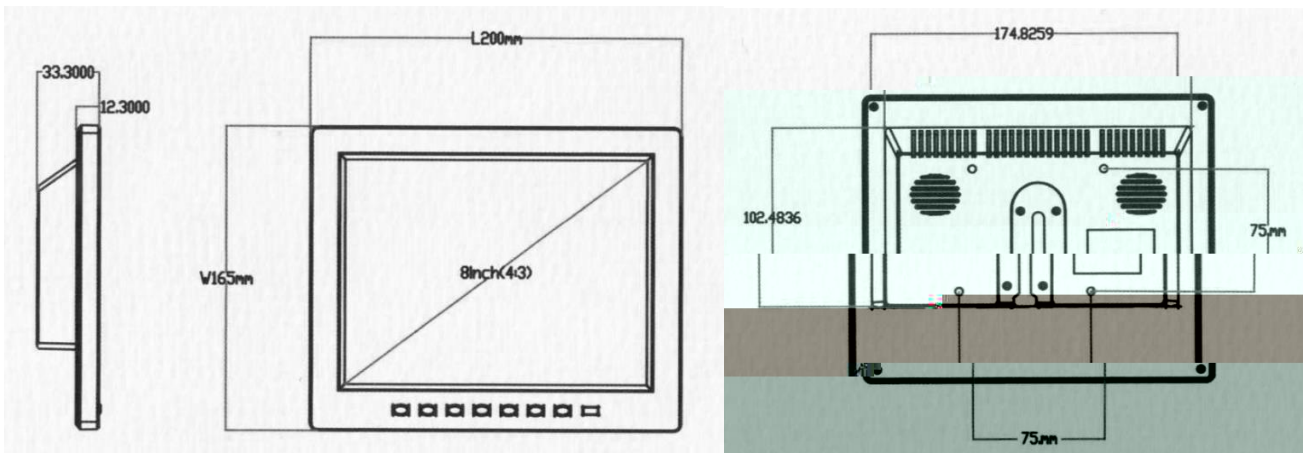
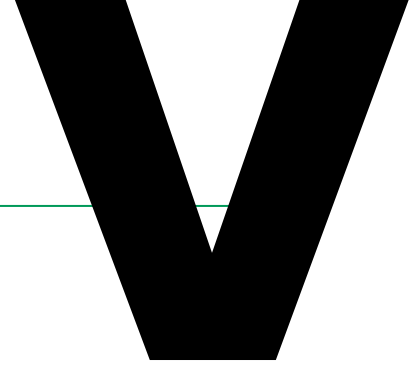

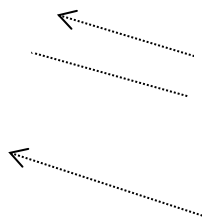
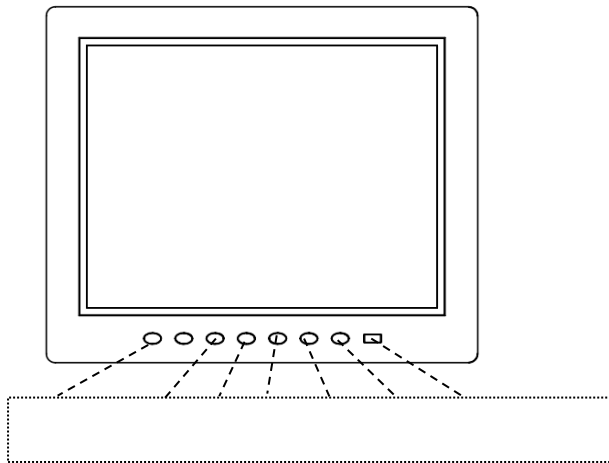
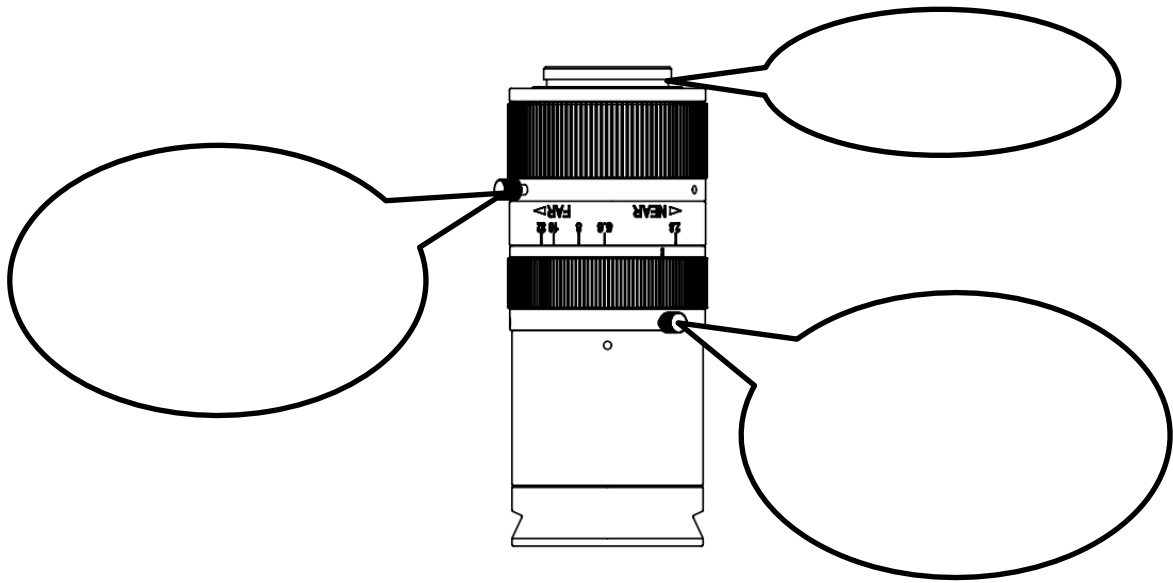

≡

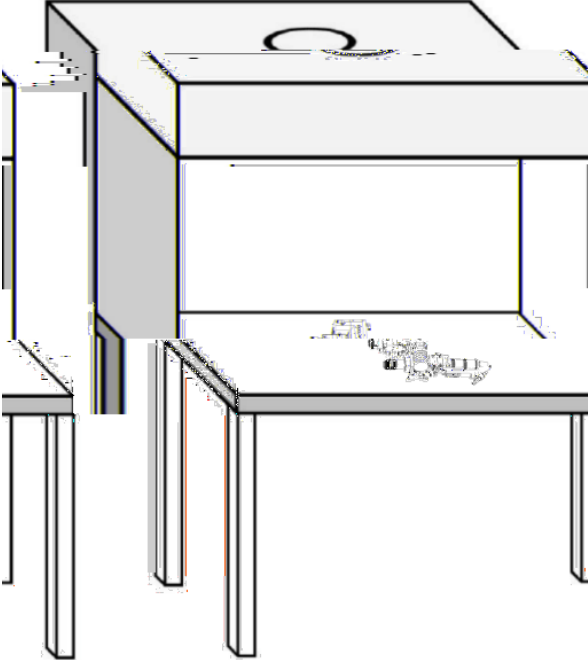

RAYTOOLS

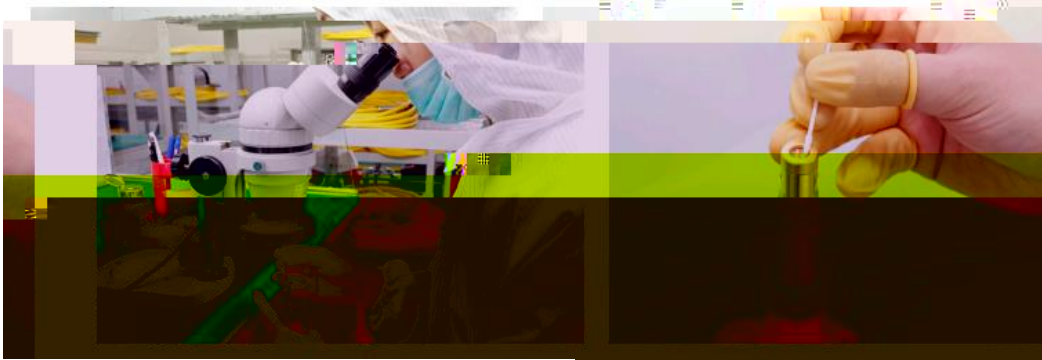
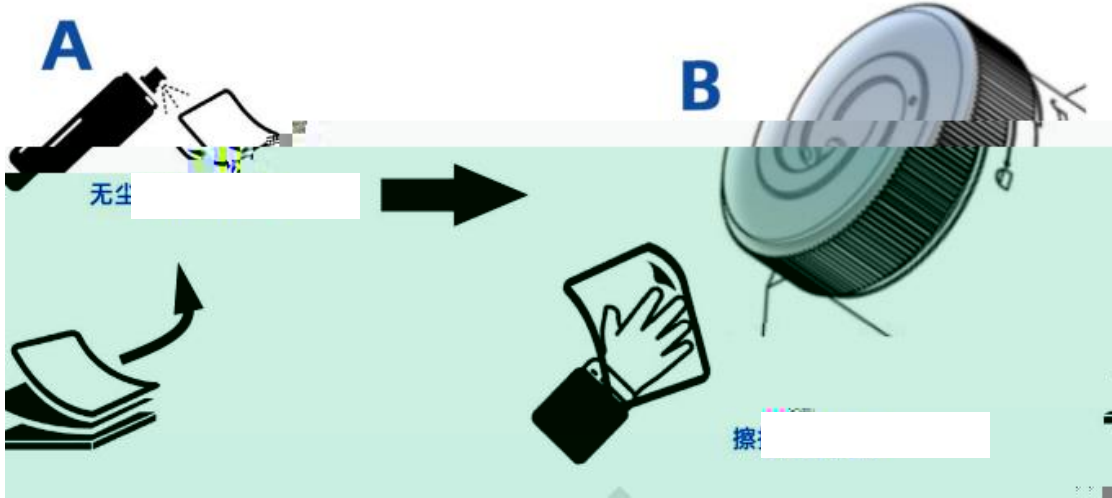

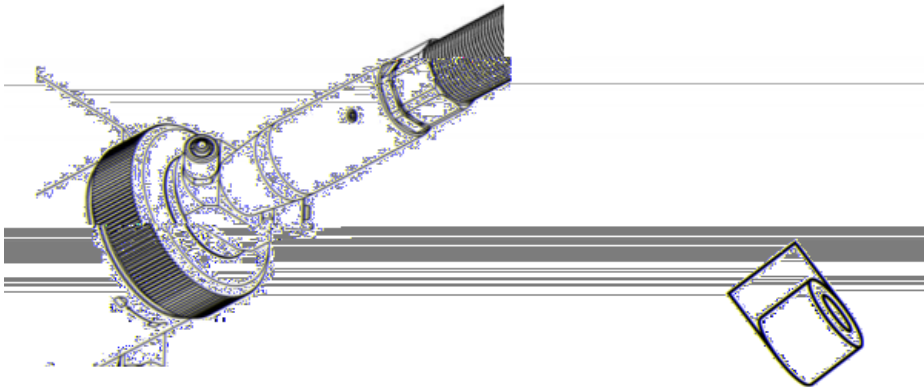
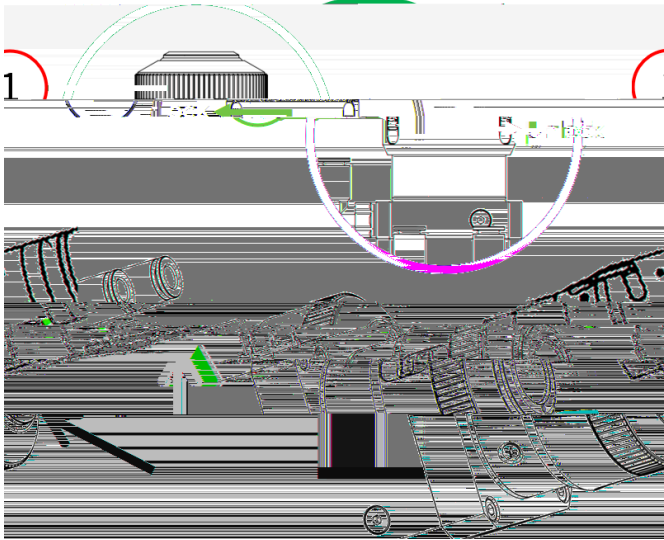

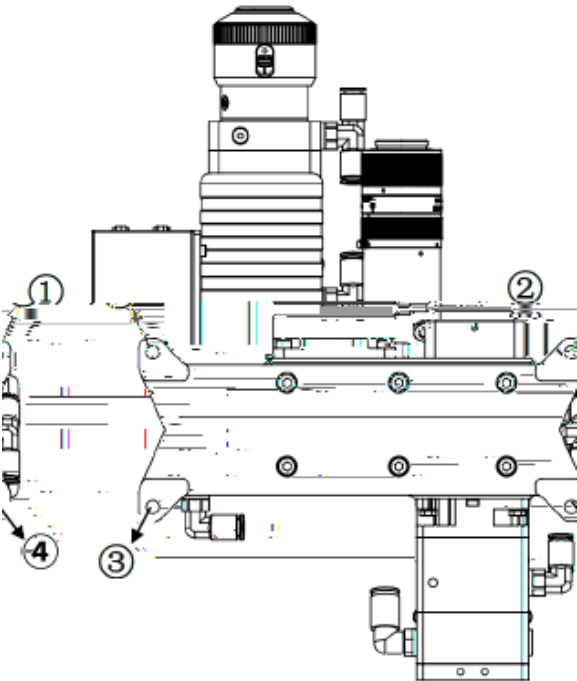

Rear View

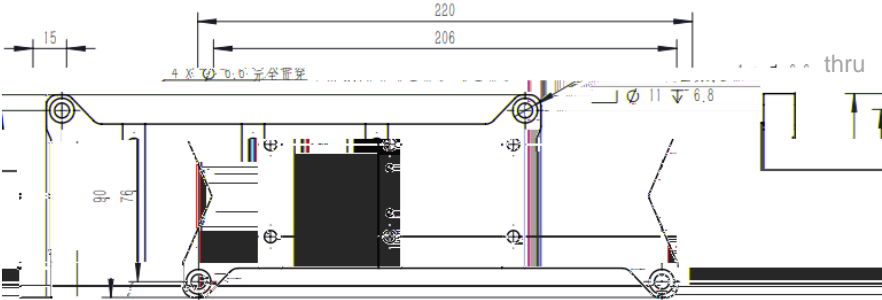

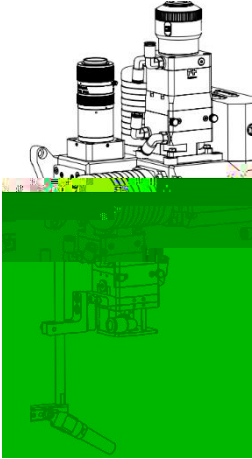
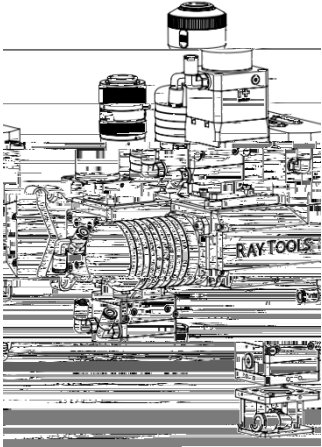
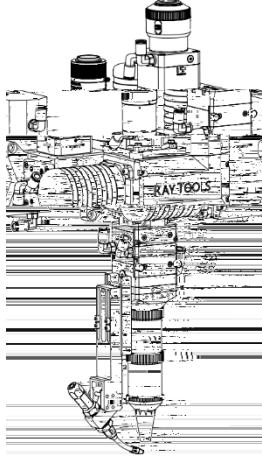
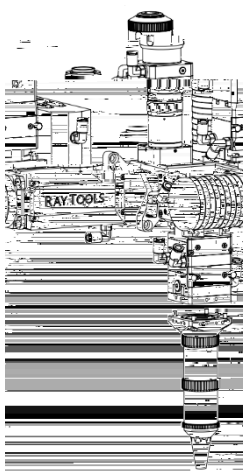
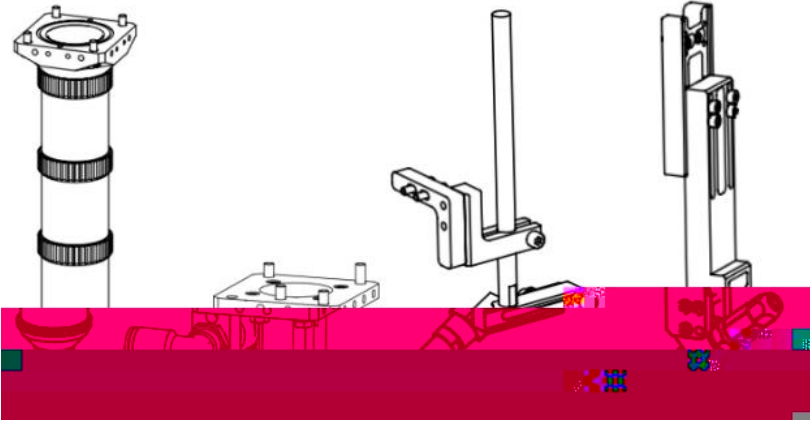

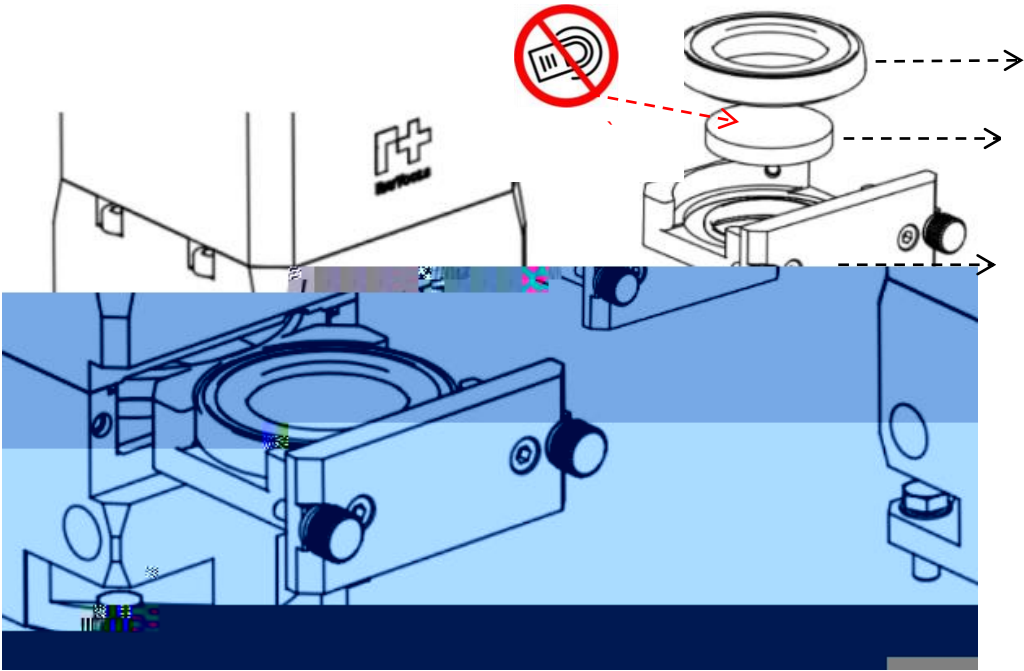

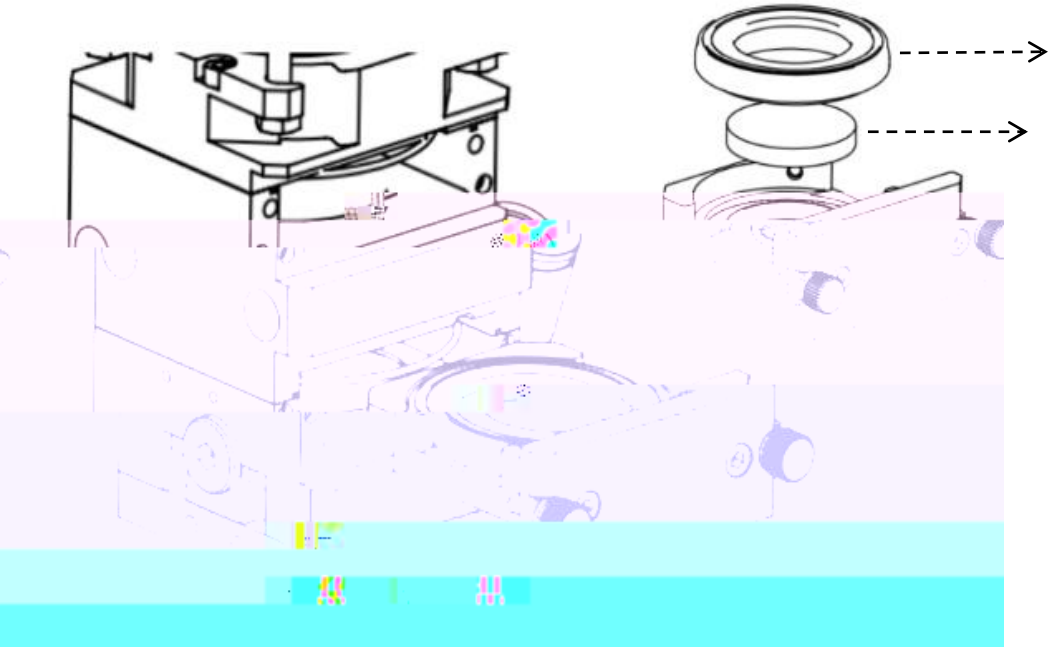

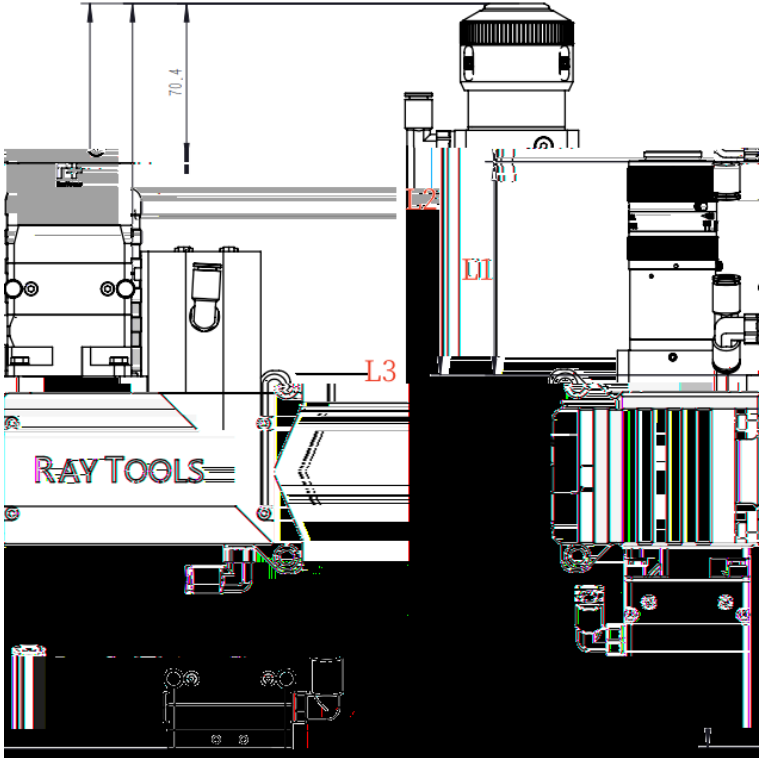

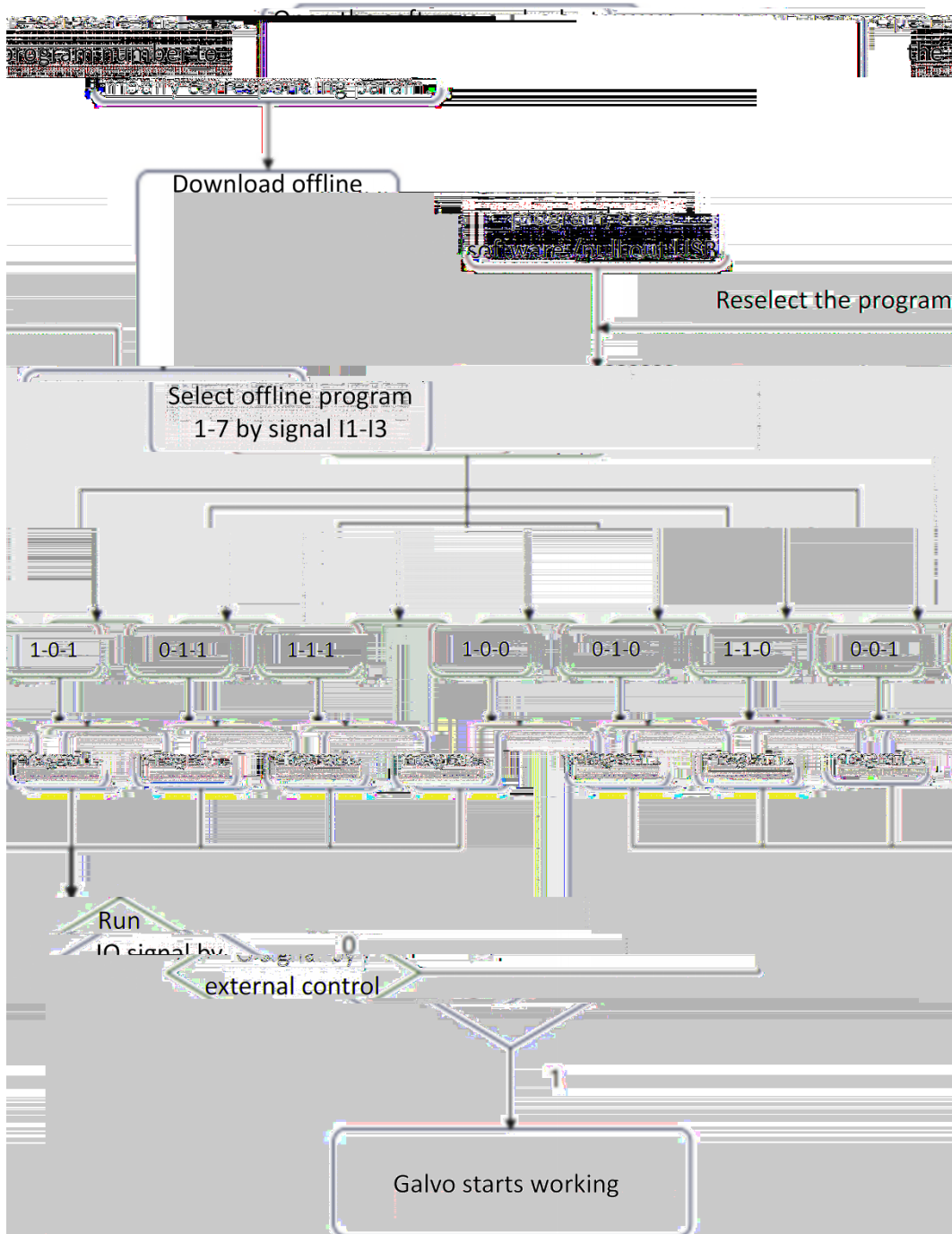

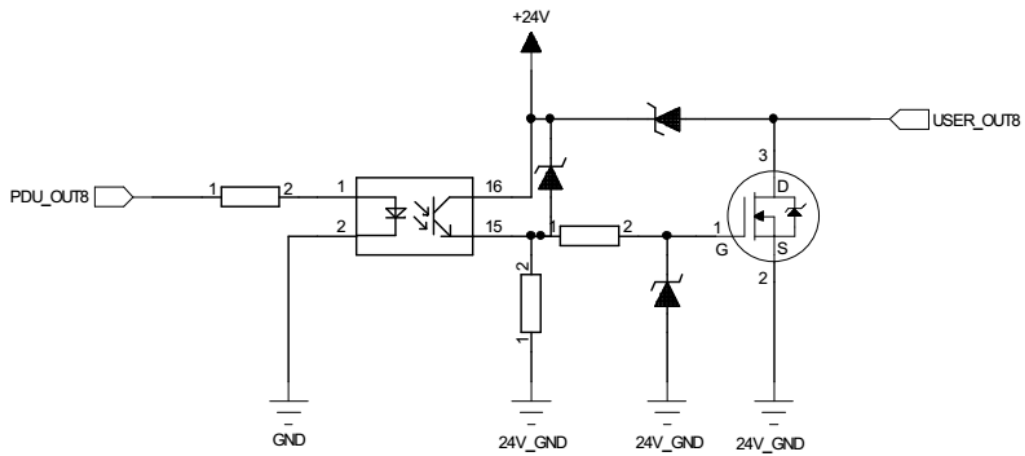
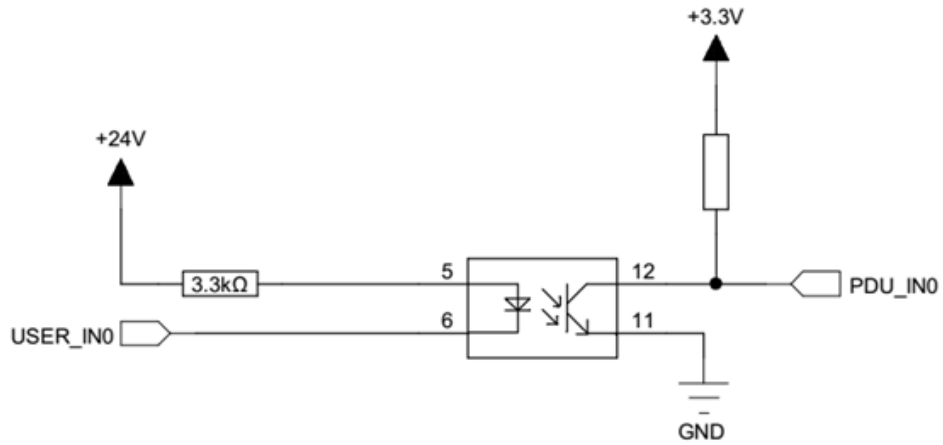



program6	2021/4/6 15:47	XM
...
Tao.Platform.Windows.dll	2021/3/23 14:31	
Tao.OpenGL.dll	2021/3/23 14:31	
Tao.Platform.Windows.dll	2021/3/23 14:31	
WeldAhead_wob	2021/4/6 16:50	
WeldAhead_wob.exe.config	2021/3/23 14:31	
WeldAhead_wob.pdb	2021/4/6 16:50	

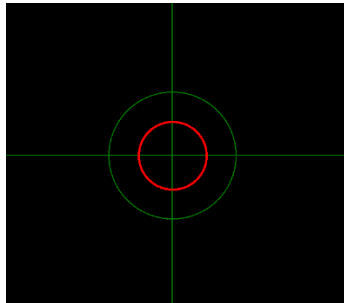

Graphics Settings

ProgramID	Program2
WeldType	Continuous Circle
Line Length	0 mm
Radius	7.49 mm
StartAngle	0 °
Spin angle	0 °
Frequency	50
X Offset	0 mm
Y Offset	0 mm

DownLoad

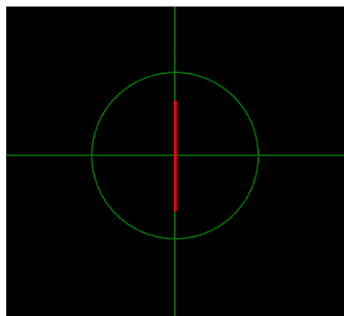

Graphics Settings

ProgramID	Program2
WeldType	Continuous Line
Line Length	2 mm
Radius	0 mm
StartAngle	0 °
Spin angle	0 °
Frequency	50
X Offset	0 mm
Y Offset	0 mm

DownLoad

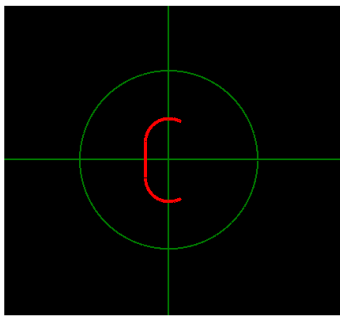

Graphics Settings

ProgramID

WeldType

Line Length mm

Radius mm

StartAngle °

Spin angle °

Frequency

X Offset mm

Y Offset mm

[Download](#)

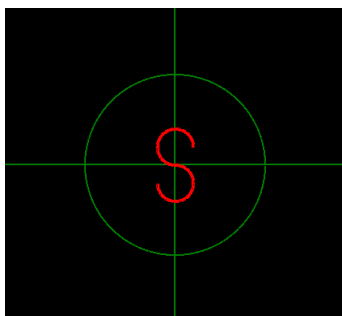

Graphics Settings

ProgramID

WeldType

Line Length mm

Radius mm

StartAngle °

Spin angle °

Frequency

X Offset mm

Y Offset mm

[Download](#)

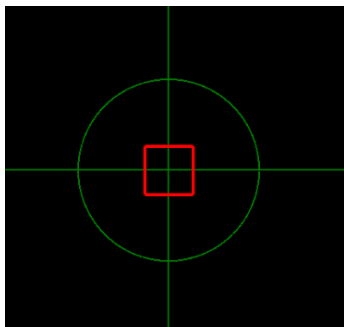

Graphics Settings

ProgramID

Continuous Square

Length mm

Radius mm

Start Angle °

Spin Angle °

Frequency mm

X Offset mm

Y Offset mm

Download

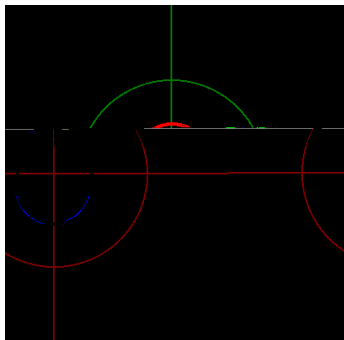

Graphics Settings

ProgramID

Continuous Ellipse

Length mm

Radius mm

Start Angle °

Spin Angle °

Frequency mm

X Offset mm

Y Offset mm

Download

